

Crystallography without crystals. I. The common-line method for assembling a three-dimensional diffraction volume from single-particle scattering

V. L. Shneerson, A. Ourmazd and D. K. Saldin*

Department of Physics, University of Wisconsin-Milwaukee, PO Box 413, Milwaukee, WI 53201, USA. Correspondence e-mail: dksaldin@uwm.edu

Received 14 March 2007
 Accepted 18 December 2007

It is demonstrated that a common-line method can assemble a three-dimensional oversampled diffracted intensity distribution suitable for high-resolution structure solution from a set of measured two-dimensional diffraction patterns, as proposed in experiments with an X-ray free-electron laser (XFEL) [Neutze *et al.* (2000). *Nature (London)*, **406**, 752–757]. Even for a flat Ewald sphere, it is shown how the ambiguities due to Friedel's law may be overcome. The method breaks down for photon counts below about 10 per detector pixel, almost three orders of magnitude higher than expected for scattering by a 500 kDa protein with an XFEL beam focused to a 0.1 μm diameter spot. Even if 10^3 orientationally similar diffraction patterns could be identified and added to reach the requisite photon count per pixel, the need for about 10^6 orientational classes for high-resolution structure determination suggests that about 10^9 diffraction patterns must be recorded. Assuming pulse and readout rates of ~ 100 Hz, such measurements would require $\sim 10^7$ s, *i.e.* several months of continuous beam time.

© 2008 International Union of Crystallography
 Printed in Singapore – all rights reserved

1. Introduction

X-ray crystallography is one of the key contributions of the physical sciences to the life sciences. Its application to biological, biochemical and pharmaceutical problems continues to enable breakthroughs (Cramer *et al.*, 2001; Gnatt *et al.*, 2001) highlighting the importance of structure to function. However, roughly 40% of biological molecules do not crystallize and many cannot easily be purified. These factors severely limit the applicability of X-ray crystallography; although more than 750 000 proteins have been sequenced, the structures of less than 10% have been determined to high resolution (Protein Data Bank, <http://www.pdb.org>). The ability to determine the structure of individual biological molecules – without the need for purification and crystallization – would constitute a fundamental breakthrough.

The confluence of five factors has generated intense interest in single-molecule crystallography by short-pulse X-ray scattering. (a) The advent of algorithms for determining phases from measured diffraction intensities by successive and repeated application of constraints in real and reciprocal spaces (see *e.g.* Fienup, 1978; Elser, 2003; Millane, 2003), with demonstrations in astronomy (Fienup, 1982), diffractive imaging of nanoparticles (Williams *et al.*, 2003; Wu *et al.*, 2005; Chapman *et al.*, 2006), biological cells (Shapiro *et al.*, 2005; Thibault *et al.*, 2006), small-molecule crystallography (Oszlányi & Sütő, 2004; Wu, Spence *et al.*, 2004), surface

crystallography (Kumpf *et al.*, 2001; Fung *et al.*, 2007) and protein crystallography (Miao *et al.*, 2001; Spence *et al.*, 2005). (b) Development of sophisticated techniques for determining the relative orientation of electron-microscope images of biological entities, such as cells and large macromolecules (see *e.g.* Frank, 2006). (c) Development of techniques for producing beams of hydrated proteins by electrospraying or Raleigh-droplet formation (Fenn, 2002; Spence *et al.*, 2005). (d) The promise of very bright ultra-short pulses of hard X-rays from X-ray free-electron lasers (XFELs) under construction in the US, Japan and Europe (Normille, 2006). (e) The prospect of overcoming the limits to achievable resolution due to radiation damage by using short pulses of radiation (Solem & Baldwin, 1982; Neutze *et al.*, 2000).

It has been suggested (Neutze *et al.*, 2000; Hajdu *et al.*, 2000; Abela *et al.*, 2007) that an experiment to determine the structure of a biological molecule might, in principle, proceed as follows. (i) A train of individual hydrated proteins is exposed to a synchronized train of intense X-ray pulses. As a single pulse is sufficient to destroy the molecule, the pulses (and data collection) must be short compared with the roughly 50 fs needed for the molecular constituents to fly apart (Neutze *et al.*, 2000; Jurek *et al.*, 2004). (ii) The two-dimensional diffraction patterns obtained with single pulses are read out, each pattern corresponding to an unknown random orientation of the molecule. (iii) The relative orientations of the molecule corresponding to two-dimensional diffraction

patterns (and hence the relative orientations of each diffraction pattern in three-dimensional reciprocal space) are determined. (iv) A noise-averaged three-dimensional diffracted intensity distribution is constructed. (v) The structure of the molecule is determined from the diffracted intensity distribution by an iterative 'phasing algorithm' (Miao *et al.*, 2001). As pointed out by Huldt *et al.* (2003), for this approach to succeed in principle, it is necessary to develop a noise-robust algorithm to determine the relative orientations of diffraction patterns obtained from randomly oriented individual molecules, to reconstruct the three-dimensional diffracted intensity distribution of sufficient quality, and to determine the secondary structure of individual biological molecules.

In brief, starting with a collection of noisy two-dimensional diffraction patterns of unknown orientation, such a method recovers the three-dimensional electron density of a molecule, providing a quantitative measure of the reliability of the reconstruction. It has been suggested that an algorithm developed for the analogous problem of reconstructing a three-dimensional image of a large molecule or nanoparticle from different projected electron-microscope images, the method of common lines, may be employed for this task. We investigate the capabilities and limitations of such an approach for structure recovery from simulated short-wavelength diffraction patterns of a small (10 residue) synthetic protein, chignolin (Protein Data Bank entry: 1uao).

Starting with 630 simulated noise-free two-dimensional diffraction patterns of 0.1 Å wavelength X-rays from random orientations of the molecule, we show that such an algorithm is able to recover the electron-density distribution of the (small) test protein molecule, chignolin, up to about 1 Å resolution with a fidelity measured by a correlation coefficient of 0.7 between the model and recovered electron-density distributions. This constitutes the first demonstration of an integrated algorithm able to perform all the tasks necessary to extract a molecular electron density from a set of two-dimensional diffraction patterns of random unknown orientations. We have also investigated the limits of the algorithm with respect to shot noise (modeled by Poisson statistics) in the detected signal. Our results show that the common-line method requires at least 10 photons pixel⁻¹. This is at least two orders of magnitude higher than the anticipated signal levels from the LCLS XFEL currently under construction.

The algorithm consists of three primary modules: (a) determination of the relative orientations of the measured diffraction patterns in three-dimensional reciprocal space; (b) from the resulting irregular distribution of diffracted intensities, application of a gridding algorithm to generate data on a uniform rectilinear grid in reciprocal space; (c) application to this gridded data of a three-dimensional iterative algorithm to find the phases associated with the grid intensities and recover the three-dimensional electron density of the molecule. For an experiment which provided independent information about the orientations of the sample, steps (b) and (c) were previously implemented by Chapman *et al.* (2006).

2. Determination of the relative orientations of the diffraction patterns

In the following, we assume that the X-ray energy is high enough and the solid angle subtended by the diffraction pattern at the sample small enough that it is a reasonable approximation to consider each diffraction pattern as a planar central section through the three-dimensional reciprocal space of the molecule. In practice, this is valid for X-ray wavelengths of about 0.1 Å. Then, the problem reduces to determining the relative orientations of these planar sections from the data in the diffraction patterns alone without any knowledge of the structure of the molecule. For longer wavelengths, as pointed out previously (*e.g.* Huldt *et al.*, 2003; Chapman, 2007), it will be necessary to take account of the curvature of the Ewald sphere when the common lines become arcs of a circle rather than straight lines. The extra complexity of identifying such arcs may be offset by two factors: (i) the avoidance of ambiguities stemming from the duplication of intensities in the same two-dimensional diffraction pattern, due to Friedel's law (see below); and (ii) the possibility of determining all three Euler angles relating the orientations of any two diffraction patterns from just their mutual common line (Huldt *et al.*, 2003) if the extra parameter of the radius of curvature of the common arcs may be determined with sufficient accuracy.

Our approach is inspired by the analogous problem of reconstructing the three-dimensional structure of a macromolecule or nanoparticle from electron-microscope images representing projections of copies of the object along random directions (Frank, 2006). This problem has been solved by exploiting the central section theorem (Farrow & Ottensmeyer, 1992), and has been developed most notably by these authors and also previously by van Heel (1987) and Goncharov *et al.* (1987). From the *projection-slice theorem*, the Fourier transform of a two-dimensional (*i.e.* projected) image is a central slice through the complex three-dimensional reciprocal space of the three-dimensional object. Any two central sections intersect along a line. This allows partial alignment of the two central sections with respect to each other. Specifically, determination of the gradients of this common line relative to, say, two-dimensional Cartesian coordinate systems in the planes of each of the central sections allows two of the three Euler angles specifying the relative orientations of these central sections to be deduced. Using this procedure, it is generally possible to determine six of the nine interplanar Euler angles from *three* independent diffraction patterns. Knowledge of these six Euler angles allows the remaining three to be deduced by geometrical construction.

We point to one important difference between an application of the common-line approach to images (as in three-dimensional electron microscopy) and diffraction patterns. The images constitute projections of the object in real space. Some applications of the central section theorem have been performed in reciprocal space, exploiting the fact that two-dimensional Fourier transforms of these images yield moduli and phases of *complex* amplitudes on central sections through reciprocal space. Sinograms of the data of any two diffraction

patterns allow the unique identification of a pair of Euler angles relating the two central sections in three-dimensional reciprocal space (Frank, 2006). In contrast, in our problem, the raw experimental data are diffracted intensities and direct information is available only about the *moduli* of the complex amplitudes in reciprocal space.

Friedel's law of crystallography suggests that the intensity distribution along a radial line through the center of each diffraction pattern is the same as one rotated relative to it by 180° . This means that, for a flat Ewald sphere, the determination of the pair of Euler angles from common lines is uncertain by $\pm 180^\circ$. Any significant curvature of the Ewald sphere removes this ambiguity but, even for a flat Ewald sphere, this uncertainty may be resolved through consistency conditions amongst the Euler angles, as shown below.

2.1. Determination of two Euler angles between two intersecting diffraction patterns

Fig. 1 illustrates the reciprocal-space geometry of two central sections, representing diffraction patterns, $P1$ and $P2$. Let the Euler angles relating $P1$ and $P2$ be Φ_{12} , Θ_{12} and Ψ_{12} . Consider three Cartesian axes X , Y and Z , where X and Y lie in the plane of $P1$ and Z is normal to it. Diffraction pattern $P2$ is related to $P1$ by a set of three rotations. The initial rotation is through the azimuthal angle Φ_{12} about the Z axis. Next follows a rotation through Θ_{12} about the X axis obtained after the first rotation. Let us denote this axis by $C12$. The final rotation is through Ψ_{12} about the new Z axis, denoted Z' . It is clear from the figure that $C12$ is the line of intersection between $P1$ and $P2$, *i.e.* the common line.

The orientation of the common line $C12$ relative to the (X, Y) Cartesian axes in the plane of $P1$ is shown in Fig. 2. The gradient m_{12} of $C12$ with respect to the (X, Y) axes in the plane of $P1$ is given by

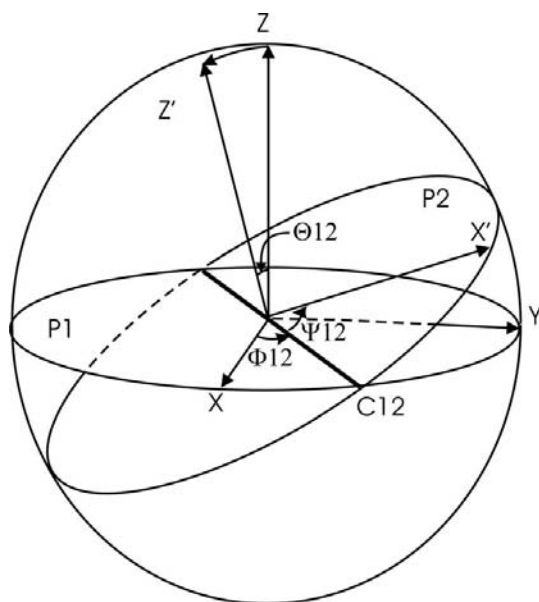

Figure 1
Transformation of central section $P1$ into $P2$ by rotation through Euler angles Φ_{12} , Θ_{12} , and Ψ_{12} .

$$m_{12} = \tan(\Phi_{12}) \quad (1)$$

and hence the Euler angle

$$\Phi_{12} = \arctan(m_{12}) \quad (2)$$

can be determined if the common line $C12$, and hence its gradient in the plane of $P1$ relative to the Cartesian axes (X, Y) , can be identified.

Now note that, since $C12$ is the common line, it must also be contained in the plane of $P2$ after the Euler-angle rotations. Its orientation relative to the Cartesian axes (X', Y') in the plane of $P2$ is depicted in Fig. 3. Its gradient m_{21} relative to the axes (X', Y') in $P2$ is

$$m_{21} = -\tan(\Psi_{12}) \quad (3)$$

and hence the Euler angle

$$\Psi_{12} = \arctan(-m_{21}) \quad (4)$$

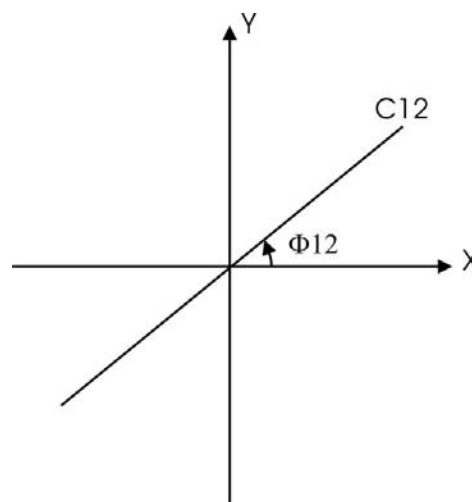

Figure 2
Orientation of common line $C12$ relative to the Cartesian axes (X, Y) in the central section of $P1$.

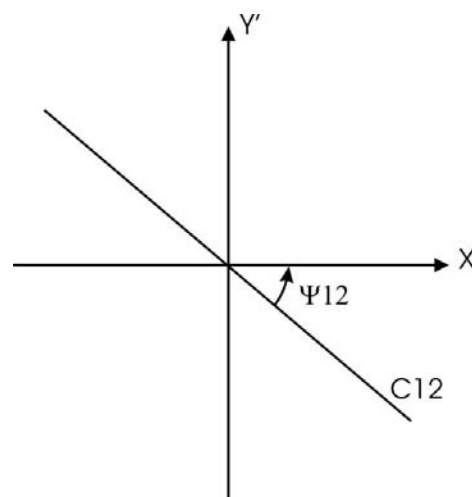

Figure 3
Orientation of common line $C12$ relative to the Cartesian axes (X', Y') after the Euler-angle rotations in the diffraction pattern $P2$.

may be determined if the common line C_{12} , and hence its gradient in the plane of P_2 relative to the Cartesian axes (X' , Y'), can be identified in the diffraction pattern in that plane.

Given two diffraction patterns, a pairwise numerical comparison [*sinogram* comparison (Frank, 2006)] of the intensity distributions along radial directions of the two patterns may be conducted. An automated criterion, such as an R factor, monitors the degree of agreement. An exhaustive search is performed of all pairs of radial distributions of the intensities on the two patterns. A global minimum of the R factor is assumed to determine the common line. For the diffraction patterns P_1 and P_2 above, denote the common line by C_{12} . This gives estimates of the Euler angles Φ_{12} and Ψ_{12} .

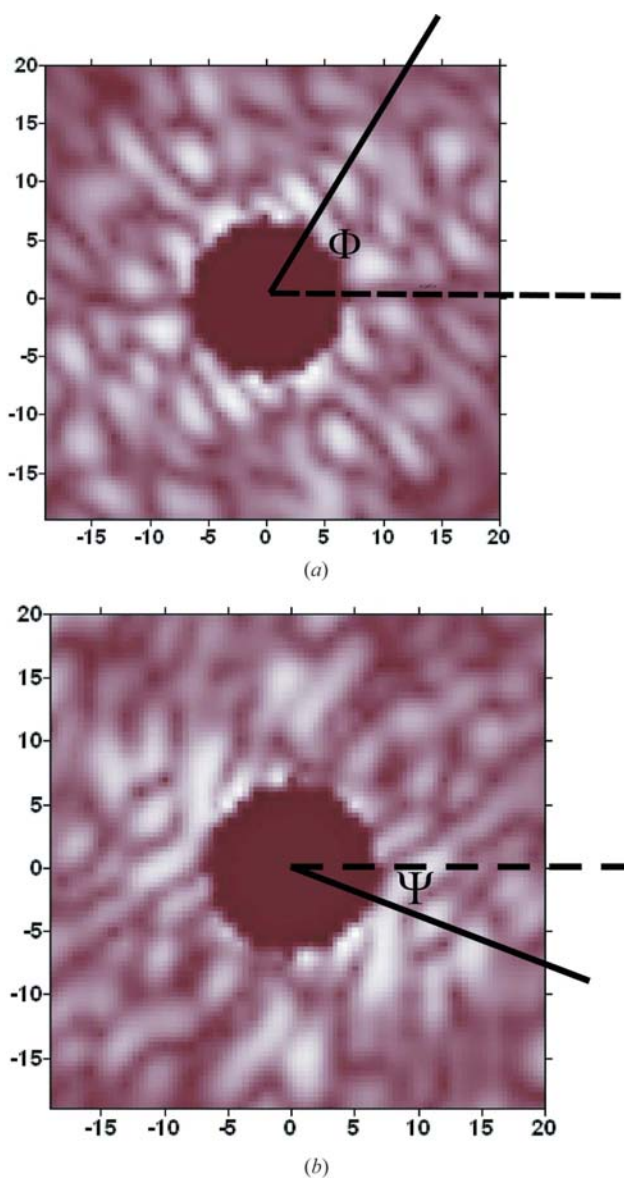

Figure 4 Identification of the common line in two typical simulated diffraction patterns from a model of the protein chignolin, leading to a determination of the azimuthal Euler angles Φ and Ψ relating the three-dimensional orientations of the diffraction patterns.

Figs. 4(a) and 4(b) show two simulated diffraction patterns (40×40 pixels) from random orientations of our test protein, chignolin. The maximum lateral wavevector in the direction of the x axis was ten times the Nyquist frequency for the assumed lateral extension of the protein (16 \AA). This corresponds to a reciprocal-space length of $q = 2\pi(10)/16 = 3.93 \text{ \AA}^{-1}$. The wavevector, k , of 124 keV hard X-rays is about 63 \AA^{-1} . The scattering angle corresponding to the middle of an edge of the square diffraction pattern was calculated from $2 \arcsin(q/2k) = 3.2^\circ$. The central part of each diffraction pattern contains high intensities of relatively low detail but several orders of magnitude stronger than in the outer parts of the pattern containing the high-resolution structural information. A numerical search for the common lines between the two patterns of Fig. 4 was performed by pairwise comparisons of the radial intensity distributions from the two patterns in angular steps of 1° , excluding the pixels within a central high-intensity disc of 7 pixels radius corresponding to a scattering angle of $\sim 1^\circ$. Effectively, the values of the azimuthal Euler angles Φ_{12} and Ψ_{12} were identified by a contour plot of the form shown in Fig. 5. The identified common lines are also shown in Figs. 4(a) and 4(b). Owing to the Friedel law degeneracy mentioned above, any 180° range of azimuthal angles would be expected to contain such a minimum. For convenience, we perform numerical searches for Φ_{12} and Ψ_{12} angles over an azimuthal angle range of 0 to 180° . Then Friedel's law suggests equally valid values for these angles of $\Phi_{12} + 180^\circ$ and $\Psi_{12} + 180^\circ$, respectively. Without phase information, it is impossible to tell from the diffraction data alone which of the two values of each angle is 'correct'.

In the case of the flat Ewald sphere considered here, it is not possible to determine the Euler angle Θ_{12} between the normals to these planes with the data in the diffraction patterns P_1 and P_2 alone. In order to determine that angle, it is necessary to have diffraction data in at least one more

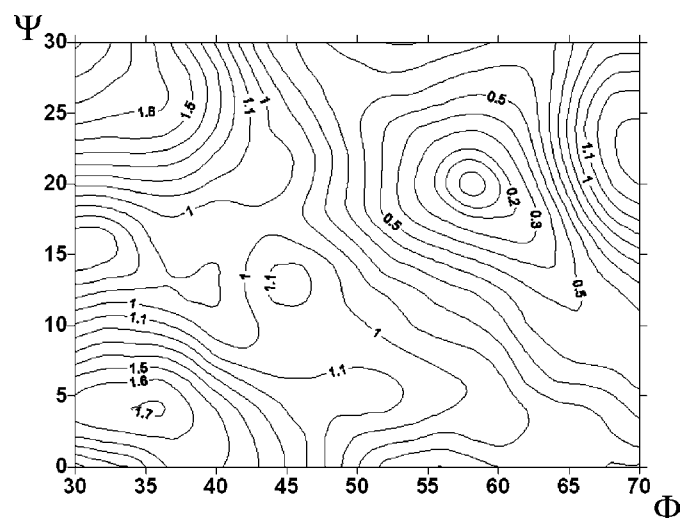

Figure 5 Contour map of sinogram comparisons between the two diffraction patterns of Fig. 4 in the vicinity of the global minimum at $\Phi = 58^\circ$, $\Psi = 21^\circ$.

distinct reciprocal-space plane, which intersects the planes of $P1$ and $P2$ along two further distinct common lines.

2.2. Determination of all nine Euler angles relating three general central sections

Let $P3$ denote a third diffraction pattern (Fig. 6). Since each diffraction pattern forms a central section through reciprocal space, each pair of diffraction patterns intersects along a common line, with the three common lines intersecting at the origin (O in Fig. 6). Denote the Euler angles specifying the transformation of the plane of $P2$ to that of $P3$ by $(\Phi_{23}, \Theta_{23}, \Psi_{23})$, and those transforming plane of $P3$ to that of $P1$ by $(\Phi_{31}, \Theta_{31}, \Psi_{31})$. In the notation of Fig. 6, the common line between $P1$ and $P2$ is denoted by OC , that between $P2$ and $P3$ by OA , and that between $P3$ and $P1$ by OB , with A , B and C representing points on the surface of a unit sphere centered on O .

By analogy with the method described in the last section, a comparison of the diffraction intensities of $P2$ and $P3$ can determine the Euler angles Φ_{23} and Ψ_{23} . Likewise, comparison of the data of $P3$ and $P1$ can determine the angles Φ_{31} and Ψ_{31} . This leaves only three angles to be determined: Θ_{12} between $P1$ and $P2$; Θ_{23} between $P2$ and $P3$; and Θ_{31} between $P3$ and $P1$.

The geometrical construction of Fig. 6 shows that the remaining Euler angles are the vertex angles $\angle ACB$, $\angle BAC$ and $\angle CBA$ of the spherical triangle ABC on the surface of the unit sphere. Also note that the lengths of the sides of this spherical triangle (the arcs CB , BA and AC) are equal to the sums of angles $\Psi_{31} + \Phi_{12} = \alpha_{312}$ (say), $\Psi_{12} + \Phi_{23} = \alpha_{123}$ (say) and $\Psi_{23} + \Phi_{31} = \alpha_{231}$ (say), respectively (expressed in radians). [For example, if we consider a transformation from plane 3 to plane 1 followed by one from plane 1 to plane 2, then the third Euler angle in the former transformation (Ψ_{31}) and the first Euler angle in the latter transformation (Φ_{12}) involve rotations in the same plane, that of $P1$.]

The cosine rule of spherical trigonometry gives

$$\cos(AB) = \cos(CA) \cos(CB) + \sin(CA) \sin(CB) \cos(\angle ACB), \quad (5)$$

that is,

$$\cos \alpha_{231} = \cos \alpha_{123} \cos \alpha_{312} + \sin \alpha_{123} \sin \alpha_{312} \cos(\Theta_{12}) \quad (6)$$

and thus

$$\Theta_{12} = \arccos \left[\frac{\cos \alpha_{231} - \cos \alpha_{123} \cos \alpha_{312}}{\sin \alpha_{123} \sin \alpha_{312}} \right]. \quad (7)$$

This expression was obtained by Goncharov *et al.* (1987) by a different argument.

Generalizing this result for a triplet of diffraction patterns i , j and k , the angle Θ_{ij} between i and j is given by

$$\Theta_{ij} = \arccos \left[\frac{\cos \alpha_{jki} - \cos \alpha_{ijk} \cos \alpha_{kij}}{\sin \alpha_{ijk} \sin \alpha_{kij}} \right], \quad (8)$$

where

$$\alpha_{ijk} = \Psi_{ij} + \Phi_{jk}, \quad (9)$$

$$\alpha_{kij} = \Psi_{ki} + \Phi_{ij}, \quad (10)$$

and

$$\alpha_{jki} = \Psi_{jk} + \Phi_{ki} \quad (11)$$

with k a third plane.

The above analysis shows that, provided the Euler angles Φ and Ψ specifying the directions of common lines between any three sets of diffraction patterns i , j and k are determined (*e.g.* by comparisons of sinograms from the diffraction patterns), the Euler angles Θ about the ‘hinge axes’ formed by the common lines amongst those diffraction patterns can be deduced by the analytic formula (8).

2.3. Removal of the ambiguities due to Friedel’s law

As pointed out in the previous section, the Euler angles Φ and Ψ may be determined from the diffraction pattern data only to modulo 180° , due to Friedel’s law. Thus, in addition to initial values (in the range 0 to 180°) assigned to these angles by the automated numerical sinogram comparison, one must also consider as possible values of these angles $\Phi + 180^\circ$ and $\Psi + 180^\circ$, respectively. The possibility of two values for each of the three Φ angles and two for each of the three Ψ angles implies four possible values of each of the α angles in expressions (9), (10) and (11). Since three distinct α angles enter into the formula (8), there are $4^3 = 64$ possible values of Θ_{ij} for a given set of Φ and Ψ angles deduced from three different diffraction patterns.

In fact, this is not the case. Many combinations of Φ and Ψ give rise to the same Θ_{ij} , and a large number of combinations result in arguments of the arccos function in (8) outside the range of -1 to 1 , giving no geometrically meaningful solution

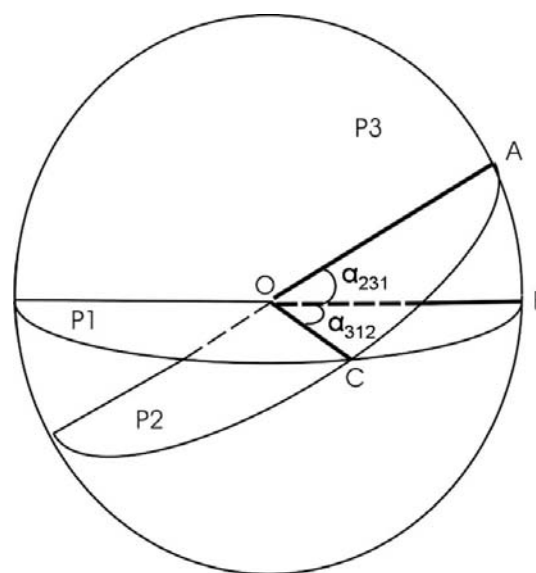

Figure 6
Geometrical construction for determining the relative Euler angle Θ_{12} between diffraction patterns $P1$ and $P2$, given the six Euler azimuthal angles Φ and Ψ relating $P1$, $P2$ and $P3$.

Table 1

Φ and Ψ Euler angles (in degrees) relating diffraction patterns from three random orientations of the molecule, as determined by numerical sinogram comparisons.

Pair	Φ	Ψ
(1, 2)	16.0	108.0
(2, 3)	173.0	174.0
(3, 1)	121.0	132.0

at all. This eliminates all but two sets of the three Θ angles. The remaining ambiguity is due to the well known enantiomeric ambiguity of molecular structures that give rise to the same diffraction intensities. This ambiguity is impossible to resolve from the diffraction data alone. An arbitrary but consistent choice of one of the two sets of Θ angles produces one of the two enantiomers of the structure.

A concrete example from a simulation of three diffraction patterns, 1, 2 and 3, from random orientations of the same molecule is illustrative. The Φ and Ψ angles of Table 1 were determined by numerical comparisons of sinograms of the three patterns.

Substituting all 64 combinations of Φ and $\Phi + \pi$, and Ψ and $\Psi + \pi$ into equations (8)–(11) results in 46 combinations with values for the cosine of the relevant angle Θ lying outside the range -1 to 1 . Nine of the 64 combinations give rise to the Θ angles in Table 2.

Another nine combinations give rise to the values for the Θ angles in Table 3.

It turns out that the two sets of values of the Θ angles determined by this method correspond to the two enantiomeric solutions referred to above. Thus the method described rules out Friedel-pair combinations of common-line directions that are unphysical, producing just the two enantiomers consistent with the diffraction data.

2.4. Averaging and self-consistency checks

A particular angle Θ_{ij} may be estimated from (8) by taking as the third diffraction pattern k any one of the $N - 2$ other diffraction patterns. Each choice of third diffraction pattern will yield two possible (usually widely separated) values of Θ_{ij} , corresponding to the two possible enantiomers. This time, since we have already chosen an enantiomer in our previous estimate of Θ_{ij} using a different third diffraction pattern, we choose the solution that is closest to the previously selected value of Θ_{ij} , *i.e.* the same enantiomer. The finally assigned value of this angle will be the average of these values computed by (8) *via* all possible third planes k , namely:

$$\Theta_{ij} = \frac{1}{N - 2} \sum_{k \neq i, k \neq j} \arccos \left[\frac{\cos \alpha_{jki} - \cos \alpha_{kij} \cos \alpha_{ijk}}{\sin \alpha_{kij} \sin \alpha_{ijk}} \right]. \quad (12)$$

The calculations of the Θ angles *via* (12), including the tests of enantiomeric consistency, are very rapid. The bulk of the computational time involves the sinogram comparisons for diffraction pattern pairs. The time for these computations scales as the total number of pairs amongst N diffraction

Table 2

One set of three (hinge) angles Θ (in degrees) between the three diffraction patterns oriented in three-dimensional reciprocal space, deduced from equation (8).

Pair	Θ
(1, 2)	114.2
(2, 3)	144.4
(3, 1)	103.4

Table 3

Another set of values of the same Θ angles (in degrees) as in Table 2, as determined by the same method.

This solution corresponds to the enantiomer structure.

Pair	Θ
(1, 2)	19.1
(2, 3)	12.1
(3, 1)	159.5

patterns, namely $N(N - 1)/2$. To save computational time for the 630 diffraction patterns, we divided them into sets of about ten diffraction patterns each. So long as two diffraction patterns are common to each of these sets of about ten, the method determines the relative orientations of all diffraction patterns relative to these two for a given enantiomer, with a computational time saving of a factor of approximately $(630/10)^2 \approx 4000$.

A method of sinogram matching determines common-line directions by comparison between pairs of projections/diffraction patterns at a time. Farrow & Ottensmeyer (1992) have suggested a method of simultaneously taking account of data from all available projections by means of quaternion mathematics. We propose here an alternative method of ensuring that all determined Euler angles are consistent with the data of all available diffraction patterns. With noisy data, such a self-consistency condition may even help reduce some of the errors due to noise. Consider any three non-coplanar diffraction patterns, i , j and k . Then,

$$R(\Phi_{ij}, \Theta_{ij}, \Psi_{ij})R(\Phi_{jk}, \Theta_{jk}, \Psi_{jk})R(\Phi_{ki}, \Theta_{ki}, \Psi_{ki}) = I, \quad (13)$$

where R is the three-dimensional rotation matrix, which transforms plane i to plane j in three-dimensional reciprocal space and I is the three-dimensional unit matrix.

Since $R(\Phi_{jk}, \Theta_{jk}, \Psi_{jk})^{-1} = R(\Phi_{kj}, \Theta_{kj}, \Psi_{kj})$, and $R(\Phi_{ki}, \Theta_{ki}, \Psi_{ki})^{-1} = R(\Phi_{ik}, \Theta_{ik}, \Psi_{ik})$, equation (13) may be rewritten as

$$R(\Phi_{ij}, \Theta_{ij}, \Psi_{ij}) = R(\Phi_{ik}, \Theta_{ik}, \Psi_{ik})R(\Phi_{kj}, \Theta_{kj}, \Psi_{kj}), \quad \forall k. \quad (14)$$

If the Φ and Ψ angles on the RHS of (14) have been found by sinogram matching and the Θ angles on the RHS *via* equation (12), equation (14) may be used to update the Euler angles Φ_{ij} , Θ_{ij} and Ψ_{ij} on its LHS. Since, for given planes i and j , there are $N - 2$ other planes k , these angles may be calculated independently from $N - 2$ equations of the form (14), and the values averaged. A different pair of planes ij can then be

selected and the procedure repeated to update the Euler angles on the LHSs of (14) relating all pairs of planes.

To summarize this section, we have described a detailed procedure for orientating in three-dimensional reciprocal space a large number of diffraction patterns from random unknown orientations of an object *without any knowledge of the structure of the object*. The recovery of a molecular electron density from such data requires the determination of the *phases* associated with these intensities. This may be done by the method of *oversampling* (Miao *et al.*, 2001), involving iterative Fourier transformations of the data from reciprocal to real space and applications of appropriate constraints in each of the spaces. A conventional fast Fourier transform (FFT) algorithm (Cooley & Tukey, 1965) requires data on a regular Cartesian grid in each space. Thus, it is necessary to perform a *gridding* operation in three-dimensional reciprocal space to prepare the data for such an iterative *phasing* algorithm.

3. Forming a regular three-dimensional diffracted intensity grid from randomly inclined central sections

We perform this three-dimensional gridding operation by means of the *MATLAB* routine, *griddata3*. This routine fits a hypersurface of the form $w = f(x, y, z)$ to the irregularly spaced data from the randomly inclined central sections in reciprocal space, using a tessellation-based linear interpolation, which incorporates the method of Delaunay triangulation (Delaunay, 1934), see Fig. 7. The density of the uniform three-dimensional grid points was chosen to ensure *oversampling* with respect to the Nyquist criterion for an object of the size of our test molecule. For the purposes of our present simulation, where the small test protein chignolin is known to be smaller than a cube of linear dimension 16 Å, we take a reciprocal-space sampling corresponding to the Nyquist frequency of a cube of double this linear dimension, namely

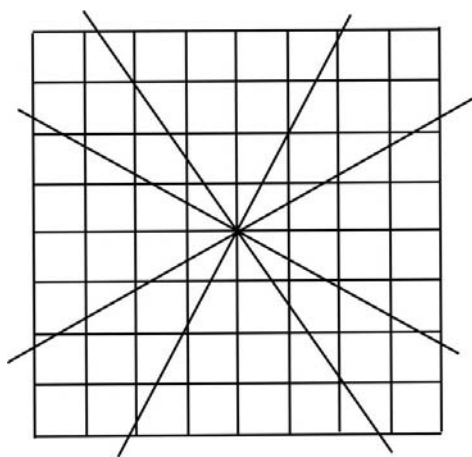

Figure 7
Two-dimensional representation of the three-dimensional gridding process. Data from regular grids on randomly oriented central sections are interpolated onto a regular rectilinear three-dimensional grid convenient for a fast Fourier transform routine.

32 Å. That is, sampling frequency of the uniform rectilinear three-dimensional reciprocal-space grid is twice the Nyquist frequency corresponding to the diameter of the object in each of the three linear dimensions.

As the test was performed on simulated data, the efficiency of the determination of the relative orientations of the simulated diffraction patterns and of the gridding algorithm could be evaluated by comparing the diffraction data on the final uniform three-dimensional Cartesian grid with diffraction intensities calculated directly on the same grid from the PDB atomic data. The usual X-ray *R* factor was used to compare the two data sets. For our simulation of 630 diffraction patterns from the protein chignolin, we obtained an *R*-factor value of 0.04, indicating a high fidelity for the orientation and gridding process.

4. Phasing of the diffraction data and the recovery of the three-dimensional molecular electron density

The determination of the phases associated with the gridded diffraction data, and hence the three-dimensional molecular electron density, was performed by a combination of an iterative *oversampling* algorithm (Miao *et al.*, 2001), which successively imposes constraints/modifications of the electron density in real space through *object domain operations* (ODO) (Fienup, 1978; Oszlányi & Sütő, 2004) and in reciprocal space (Oszlányi & Sütő, 2005).

The three-dimensional Fourier transform of the gridded diffraction *intensities* yields the three-dimensional autocorrelation function of the molecular electron density. Since the extent of the autocorrelation map is twice that of the electron-density map, the approximate spatial extent of the molecular electron density can be found directly from the diffraction intensities (Marchesini *et al.*, 2003).

A flow chart and pseudo-code of our iterative phasing algorithm is shown in Fig. 8. The square roots of the gridded diffraction intensities are assumed proportional to the protein structure factors $F_{\mathbf{q}}$, say, where a reciprocal-space vector \mathbf{q} is defined by

$$\mathbf{q} = h\mathbf{b}_1 + k\mathbf{b}_2 + l\mathbf{b}_3, \quad (15)$$

where the unit vectors \mathbf{b}_i ($i = 1, 2, 3$) of the reciprocal space are defined by the usual relationships

$$\mathbf{b}_i \cdot \mathbf{a}_j = \delta_{ij} \quad (16)$$

with respect to real-space unit vectors \mathbf{a}_j so chosen as to define a three-dimensional volume expected to contain the molecule. Since the phases associated with these structure factors are initially unknown, we begin by assigning random phases to those structure factors $F_{\mathbf{q}}$ corresponding to values of the Laue index $l \geq 0$. Assumption of Friedel's law,

$$F_{-\mathbf{q}} = F_{\mathbf{q}}^*, \quad (17)$$

then allows the assignment of complex structure factors for $l < 0$. An (inverse) FFT algorithm calculates an initial three-dimensional electron-density distribution, whose reality (in the mathematical sense) is assured by the above Friedel

relationship amongst the structure factors. In general, the computed electron density is spread over a real-space volume larger than that of the molecule. A support constraint is now applied in real space by setting to zero the electron density outside the volume expected to be occupied by the protein (Fienup, 1978). In addition, the electron density within the expected volume of the protein is modified according to the *charge flipping* prescription of Oszlányi & Sütő (2004) [which was shown by Wu, Weierstall *et al.* (2004) to be a special case of Fienup's (1982) output–output algorithm with feedback parameter $\beta = 2$]. According to the charge flipping prescription, electron-density values that exceed a certain threshold δ are unmodified, while the signs of those below this threshold are reversed. The value of this threshold is chosen to optimize the progress of the algorithm, as monitored by an *R* factor between the gridded 'experimental' structure factors and those calculated from a Fourier transform of the electron density recovered by the algorithm. (The value for δ taken in practice was typically around 10% of the maximum electron density.) A Fourier transform of the modified electron density specifies the same distribution in reciprocal space. The continued reality of this modified electron density ensures that the resulting calculated structure factors have phases satisfying Friedel's law.

A different threshold is employed to divide the reciprocal-space amplitudes into *strong* and *weak* reflections. The magnitude of the threshold amplitude was again monitored by the same *R* factor as for the real-space threshold above. The optimum division was found when 55% of the weakest reflections were classified as weak. A reciprocal-space constraint is applied to the strong reflections: their amplitudes (or moduli) are replaced by the square roots of the corresponding *measured* intensities, while retaining the phases from the Fourier transform operation. As for the weak reflections, their moduli are left unchanged, but their phases are shifted by

$\pi/2$. The resulting set of complex structure factors is then subject to an inverse Fourier transformation, which yields another real-space electron distribution. This is modified in the same way as before, and the whole process repeated for several iterations. This algorithm constrains the solution to be consistent with the measured intensities of the strong reflections in reciprocal space, and to the expected size of the object in real space. Subject to these constraints, it allows a thorough exploration of configuration space by iteratively modifying the phases of the weak reflections in reciprocal space and the signs of the small electron densities in real space.

5. Results for noise-free simulations

We have tested the effectiveness of this algorithm on a set of 630 simulated diffraction patterns computed out to about 1 Å resolution from random orientations of the small synthetic protein chignolin, simulated from the atomic elements and coordinate data taken from the Protein Data Bank and atomic scattering factors calculated from the relevant Cromer–Mann coefficients (Cromer & Mann, 1968).

We then employed our common-line method to determine the Euler angles specifying the relative orientations of each of the simulated diffraction patterns. A typical comparison of the recovered angles with the known angles from the simulations is shown in Table 4.

Occasionally, the common-line search (§2) does not succeed in accurately finding the Euler angles Φ and Ψ relating a pair of diffraction patterns. If an angle Θ is calculated from such inexact values, the calculated argument of the arccosine in equation (8) may not lie in the range +1 to –1 and thus may not yield a value for the Euler angle Θ . As shown by Table 4, this is the case for the Θ angle relating diffraction patterns (0, 9) and (0, 10). In such cases, we simply ignore the data in diffraction patterns 9 and 10. Proceeding in this way, we were

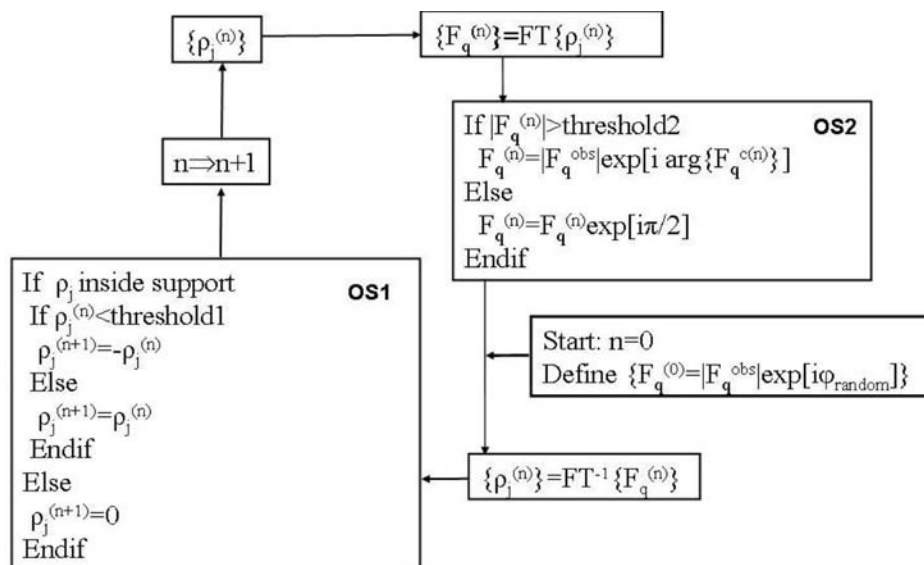

Figure 8
Flow chart and pseudo-code of the iterative phasing algorithm.

Table 4

Relative orientations of copies of a single molecule, as specified by a set of Euler angles Φ , Θ and Ψ , and the same angles recovered by the identified common lines between pairs of the diffraction patterns (reciprocal-space planes) labeled 0 to 10, and analytical formulae described in the text.

Also shown are the mean absolute errors in the determinations of these angles (all angles specified in degrees).

Pair of planes	Recovered/actual Φ	Recovered/actual Θ	Recovered/actual Ψ
(0, 1)	64.0/64.3	148.2/144.6	48.0/48.3
(0, 2)	16.0/20.8	18.7/20.6	2.0/177.6
(0, 3)	48.0/48.7	79.3/81.8	90.0/90.4
(0, 4)	144.0/140.5	40.8/43.5	118.0/122.4
(0, 5)	16.0/13.9	14.2/16.0	108.0/110.3
(0, 6)		Not found	
(0, 7)	174.0/174.2	138.9/138.2	100.0/99.6
(0, 8)	90.0/90.0	92.3/87.9	168.0/169.7
(0, 9)		Not found	
(0, 10)		Not found	
Mean error	1.7	2.5	2.0

Table 5

Comparison of the determination of the relative Euler angles of the same 11 diffraction patterns as for the noise-free case of Table 4 for noisy diffraction patterns with mean photon count of 10 photons pixel⁻¹, with the (shot) noise modeled by a Poisson distribution.

Pair of planes	Recovered/actual Φ	Recovered/actual Θ	Recovered/actual Ψ
(0, 1)	68.0/64.3	150.6/144.6	52.0/48.3
(0, 2)	14.0/20.8	18.1/20.6	4.0/177.6
(0, 3)	48.0/48.7	85.6/81.8	92.0/90.4
(0, 4)		Not found	
(0, 5)		Not found	
(0, 6)		Not found	
(0, 7)	174.0/174.2	144.3/138.2	100.0/99.6
(0, 8)		Not found	
(0, 9)		Not found	
(0, 10)		Not found	
Mean error	2.8	4.6	3.0

able to determine self-consistent solutions for the orientations of 401 out of the 630 diffraction patterns simulated. For our sample of 11 diffraction patterns, the mean accuracy of the Euler-angle determination is about 2°. We used the data of the 401 correctly oriented diffraction patterns to assign intensities to an irregularly spaced set of points in reciprocal space.

Is this sufficiently accurate? In order to answer this question, one has to ask how accurately one needs to determine these angles to correctly assign intensities in each of the points of an oversampled three-dimensional reciprocal-space grid. The required angular accuracy is thus determined by the angular extent of a reciprocal-space voxel of the highest resolution subtended at the origin of reciprocal space. Since the width of a reciprocal-space voxel is $1/(2L)$ (Huldt *et al.*, 2003), where L is a linear dimension of the molecule investigated, the angular resolution required is $1/(2L)/(1/R) = R/(2L)$ rad, where R is the required resolution. For the example of the small protein modeled here, taking $L = 15 \text{ \AA}$ and $R = 1 \text{ \AA}$, we may deduce that the required angular reso-

lution is about 1/30th of a radian, or about 2°. Table 4 shows that this is achieved.

Application of the gridding algorithm of §3 produced a set of diffraction intensities on such a uniform grid of points in three-dimensional reciprocal space. Subsequent application of the iterative phasing algorithm of §4 recovered the electron-density distribution in the lower panel of Fig. 9 in about 65 iterations of the phasing algorithm.

For purposes of comparison, we also simulated the complex structure factors (amplitude and phase) on the same oversampled three-dimensional grid of reciprocal-space points as used in the iterative phasing algorithm. An inverse Fourier transform of these (correct) complex structure factors

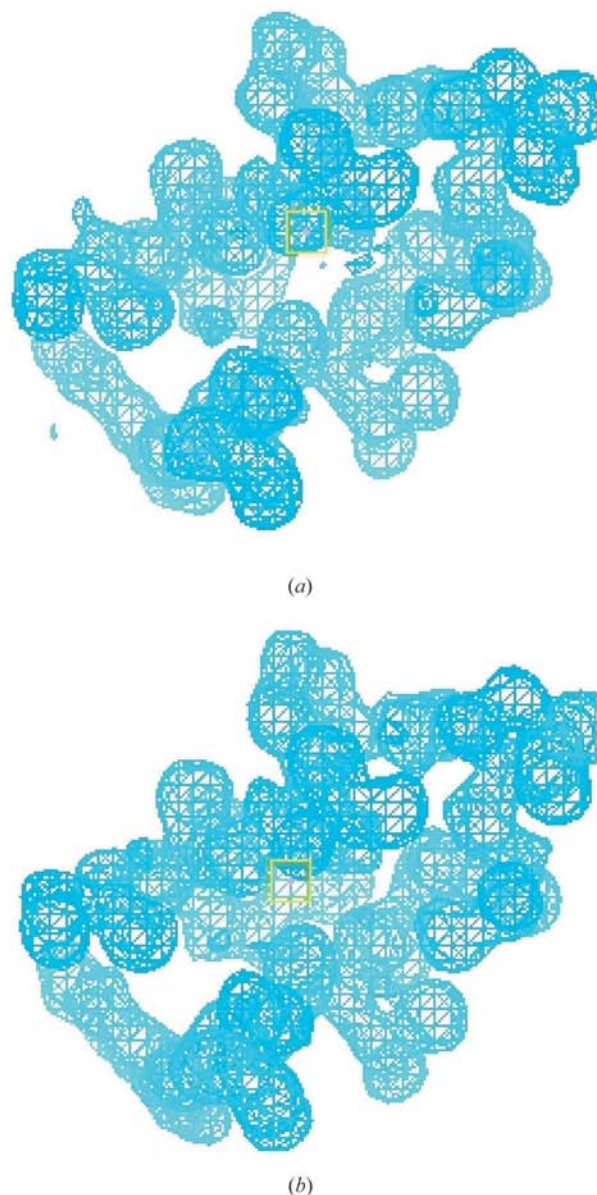

Figure 9 Electron density of protein chignolin (PDB entry: 1uao) to about 1 Å resolution. Upper panel from PDB model. Lower panel from multiple diffraction patterns of molecule in random orientations. The secondary structure is clearly visible.

Table 6

Expected counts of detected photons pulse⁻¹ pixel⁻¹ for both small-*q* and large-*q* scattering by a 500 kDa protein with an XFEL source.

E represents the photon energy, λ , its wavelength, σ_C , the typical differential scattering cross sections for a C atom for small/large *q*, *D* the assumed diameter of a focused beam incident on the sample, *W* the photon fluence, and *n* the estimated scattered photon count per pulse per detector pixel.

<i>E</i> (keV)	λ (nm)	σ_C (mm ² sr ⁻¹ , $\times 10^{-22}$)		<i>D</i> (μ m)	<i>W</i> (photons mm ⁻² pulse ⁻¹)	<i>n</i> (photons pulse ⁻¹ pixel ⁻¹)	
		Small <i>q</i>	Large <i>q</i>			Small <i>q</i>	Large <i>q</i>
12.4	0.1	2.87	0.26	1	2.6×10^{18}	50	1.4×10^{-4}
				0.1	2.6×10^{20}	5000	1.4×10^{-2}

recovered the protein electron-density distribution in the upper panel of Fig. 9 at a resolution consistent with the extent of the diffraction data.

The recovered electron density is in reasonable agreement with that of the starting model, with a correlation coefficient of 0.7 between the two electron-density distributions.

6. Effect of shot noise in measured diffraction patterns

Even with radiation from an ultra-bright source such as an XFEL, the expected number of detected photons per pixel of a diffraction pattern from a single biomolecule is expected to be very small. Therefore, it is important to investigate the robustness of any algorithm to shot noise. We do this by assuming different mean photon counts per pixel \bar{I}_0 in the high-resolution (or high-*q*) part of the diffraction pattern. If \bar{I}_0 is the expectation value of the photon count at any particular pixel, the actual number *I* of detected photons is determined by the Poisson distribution

$$p(I/\bar{I}_0) = \frac{\bar{I}_0^I}{I!} \exp(-\bar{I}_0), \quad (18)$$

where $p(I/\bar{I}_0)$ is the probability of measuring *I* photons. By comparing with the noise-free simulations, we investigated the effectiveness of the common-line algorithm in determining the relative Euler angles of the same diffraction patterns 0–10 of Table 4 for mean photon counts per pixel $\bar{I}_0 = 100$ and $\bar{I}_0 = 10$.

The results of Table 4 were almost perfectly reproduced for $\bar{I}_0 = 100$, but there was substantial deterioration of the fidelity of the determined Euler angles for a mean photon count of $\bar{I}_0 = 10$ (Table 5).

In the same subset of ten diffraction patterns, the algorithm was able to determine just four sets of relative Euler angles out of ten, with a mean angular accuracy of about 3.5°. We stated earlier that the required angular resolution is $R/(2L) = 2^\circ$ for 1 Å resolution. This may be relaxed to about 4° if 2 Å resolution is accepted. However, the fact that the orientations of less than half the diffraction patterns could be determined suggests that a mean detected photon counts pulse⁻¹ pixel⁻¹ of 10 is close to the practical lower limit for the direct use of a common-line approach. Of course, our current simulations were performed for a small protein and we have not explicitly tested the dependence of this limit on protein size. However, it is of interest to note that a similar limit of counts per pixel is typical for cryoelectron microscopy of biological entities.

The significance of these results becomes apparent on comparing these values of \bar{I}_0 with the estimated values of the same quantity under the usual assumptions of the incident-beam flux from an XFEL for two different values of the focused beam diameter *D*, as shown in Table 6.

In compiling this table, we assumed that the molecule consists of N_{atom} non-H atoms (for the present purpose modeled as C atoms). We also distinguished between small-*q* and large-*q* scattering (where *q* is the scattering-induced momentum change of an incident photon) for the following reason. There is a large difference between the expected photon count for low-*q* and for high-*q* scattering. Put simply, all electrons in the sample scatter more or less *in phase* in the low-*q* regime, thereby giving rise to a scattered intensity proportional to N^2 , where *N* is the number of electrons in the sample ($\simeq ZN_{\text{atom}}$, with *Z* the average atomic number, and N_{atom} the number of atoms), while, in the high-*q* regime, the scattered intensity is proportional to *N*.

Values for the differential scattering cross section of 12.4 keV X-rays by a C atom for small-*q* and large-*q* scattering were taken from the tables on elastic photon–atom scattering posted at the web site of the Lawrence Livermore National Laboratory (<http://www-phys.llnl.gov/Research/scattering>). Taking the effective width of a pixel as $\Delta k = 2\pi/(2L)$ (Huldt *et al.*, 2003), where *L* is a linear dimension of the molecule, implies a reciprocal-space pixel area of $(\Delta k)^2 = 4\pi^2/(4L^2)$. The solid angle subtended at the sample by each pixel is then

$$\Omega = (4\pi^2/4L^2)/k^2 = \lambda^2/4L^2 \text{ sr}, \quad (19)$$

where *k* is the wavenumber of the radiation and λ the wavelength. If *a* is the average spacing of non-H atoms, we may take $(L/a)^3 \sim N_{\text{atom}}$ or $L \sim aN_{\text{atom}}^{1/3}$. Substituting this value for *L* in (19), we deduce

$$\Omega \sim \frac{\lambda^2}{4a^2} N_{\text{atom}}^{-2/3} \text{ sr}. \quad (20)$$

For high *q*, the measured photon count per pulse per pixel (*n*) is estimated as

$$n \sim \Omega N_{\text{atom}} W \sigma_C = \frac{\lambda^2}{4a^2} N_{\text{atom}}^{1/3} W \sigma_C, \quad (21)$$

with a similar expression for low *q*, but with an $N_{\text{atom}}^{4/3}$ dependence. Taking $N_{\text{atom}} = 35\,000$ (corresponding to a protein of approximately 500 kDa molecular weight), values for λ , σ_C , *D* and *W* given in Table 6 and *a* taken as 2 Å, we deduce the values for *n* for small/large momentum transfer *q* shown in the right-hand columns of Table 6.

It is important to note that, even for a focused beam diameter of 0.1 μm , the expected photon count per pixel for large- q data (needed for high-resolution structure determination) is approximately three orders of magnitude lower than the level at which the common-line method is able to reliably find the relative orientations of the diffraction patterns.

The estimates of Table 6 suggest that the photon counts in the low- q region of a single diffraction pattern of a large protein may be high enough to render the effects of shot noise negligible. However, it is unlikely that structural information directly available from low- q data will yield anything more than the overall shape of the scattering object, as in the technique of small-angle X-ray scattering (SAXS). It is an open question whether a coarse orientating of patterns, which may be performed with the low- q data, will help to orientate entire diffraction patterns sufficiently accurately to exploit the high- q data for high-resolution structure determination.

7. Discussion

The ability to record and sort two-dimensional diffraction patterns from individual molecules is important for a number of reasons. First and most obvious is the elimination of the need for crystals. Second, and in our view equally important, is the potential to sort and separate diffraction patterns from different molecules or different molecular conformations in the beam prior to structure recovery. The fact, for example, that two-dimensional diffraction patterns from different molecules do not have common lines might allow the diffraction patterns to be separated into sets before further analysis, with each set designating a different type of molecule or molecular conformation.

This paper has been concerned with developing an algorithm to determine the structure of a single-scattering entity (such as a protein or nanoparticle) from multiple diffraction patterns due to scattering from unknown random orientations of identical copies of the object. We have shown that an adaptation of a 'common-line' algorithm from three-dimensional electron microscopy/tomography is able to accomplish this task for noise-free diffraction patterns in the flat Ewald sphere limit. There is little doubt that an extension of such a method to curved common lines will similarly enable structure determination from low-noise diffraction patterns at $\sim 1 \text{ \AA}$ wavelengths characteristic of currently planned XFELs (Hajdu *et al.*, 2000; Abela *et al.*, 2007).

Of much greater concern is that fact that, even with the most powerful XFELs currently envisaged, the expected number of scattered photons per high- q pixel of a molecular diffraction pattern from a single radiation pulse is far too low for the alignment approaches proposed so far. The common-line method relies on identifying similar intensity distributions along *single lines* in two low-intensity (and thus high-noise) diffraction patterns. As such, it is hardly surprising that it is very sensitive to noise. Our conclusion is that such a method requires a mean photon count of at least 10 per pixel in the high- q region of a diffraction pattern, about three orders of

magnitude greater than expected from a proposed experiment with an XFEL (Table 6).

We note that, in the proposed experiments, the minimum photon count per diffraction pattern orientation is not determined by the minimum required to reconstruct a satisfactory three-dimensional image of the object from projections of known orientations, as in conventional tomography, but rather by the need for correct classification and assembly of a three-dimensional diffraction volume from data in diffraction patterns alone. The minimum photon count in the former case may be quite low, since the dose fractionation theorem for three-dimensional electron microscopy/tomography (Hegerl & Hoppe, 1976; McEwen *et al.*, 1995) states that '*A three-dimensional reconstruction requires the same integral dose as a conventional two-dimensional micrograph provided that the level of significance and resolution are identical.*' This suggests that, if there are M projections (or in our case, diffraction patterns), the photon count per pixel required for an equally successful three-dimensional reconstruction will be just $1/M$ of that for a single projected image (in our case a single diffraction pattern). In the absence of orientational information, this theorem does not help because a much higher photon count (about 10 photons pixel⁻¹ per orientational class) is needed for the successful assembly of a three-dimensional diffraction volume suitable for structure solution. In short, the minimum photon count for correct classification and orientation is much higher than that needed for structure recovery of a single biomolecule.

We now consider the possibility of classifying measured diffraction patterns into sets of similar orientations and averaging their intensities to improve their signal-to-noise ratios. Bortel & Faigel (2007) find that successful classification of measured diffraction patterns of a protein modeled by 35000 C atoms requires an incident photon fluence of $10^{28} \text{ m}^{-2} \text{ pulse}^{-1} = 10^{22} \text{ mm}^{-2} \text{ pulse}^{-1}$. Comparison with our Table 6 shows that this is $100\times$ the fluence expected from an XFEL beam focused down to a 0.1 μm diameter spot. Even if a more efficient method of classification were found, Table 6 indicates that the number of photons expected per high-resolution pixel of the diffraction pattern is $\sim 10^{-2}$, approximately three orders of magnitude smaller than that needed for the common-line method. This suggests the need for the summation of the data from about 1000 diffraction patterns per orientational class. Since Bortel & Faigel also find that about 10^6 classes are required for faithful recovery of the structure of such a molecule (assumed to be 100 \AA in diameter) to 3 \AA resolution, it will be necessary to measure $\sim 10^9$ diffraction patterns. Assuming photon pulse and readout rates of $\sim 100 \text{ Hz}$, appropriate for the Linac Coherent Light Source (LCLS), the XFEL first projected to produce hard X-ray photons, this would require $\sim 10^7 \text{ s}$, or several months of continuous beam time for a single experiment.

We note that the classification problem is not eased for an even larger scattering object, such as a virus or nanoparticle. Equation (21) suggests that the number of photons per detector pixel varies as $N_{\text{atom}}^{1/3}$. Thus, a scattering entity modeled by $N_{\text{atom}} = 10^6$ C atoms would scatter three times as

many photons into each pixel. However, Bortel & Faigel (2007) estimate the number of required orientational classes for the structure solution of such an entity (assumed to be of 300 Å diameter) to 3 Å resolution is 2×10^7 , an extra factor of about 30 or so over the 500 kDa protein. The total number of diffraction patterns required would be expected to increase by the same factor, and hence time for data collection would be expected to increase to $\sim 10^8$ s, *i.e.* several years for a single experiment at the pulse and readout rates assumed above.

Assembling a three-dimensional intensity distribution from the low-intensity diffraction patterns from single molecules obtainable from single pulses of an XFEL may not be practical with the common-line method, the only approach mentioned in the literature so far (see *e.g.* the *Technical Design Report of the European XFEL*, Abela *et al.*, 2007). This calls for the development of entirely new algorithms that perform structure solution by simultaneously acting on all the data of all measured diffraction patterns. Two such approaches have been suggested by the present authors (Ourmazd *et al.*, 2007; Saldin *et al.*, 2007) and will be the subject of forthcoming publications.¹

8. Conclusions

We have presented the first demonstration of an integrated algorithm to determine the electron density of a particle or large biomolecule, such as a protein, from a collection of two-dimensional diffraction patterns, each from a molecule in an unknown random orientation, as expected from the proposed X-ray scattering experiments with XFEL sources. The method involves first determining the relative orientations of the different two-dimensional diffraction patterns, interpolating the data onto a regular three-dimensional Cartesian grid in reciprocal space at a sampling rate higher than the Nyquist frequency for the size of the molecule, determining the phases associated with the measured amplitudes, and hence deducing the three-dimensional electron density of the molecule or nanoparticle. There are significant differences with similar algorithms developed previously for three-dimensional electron microscopy, owing to the absence of direct phase information and the ambiguities due to Friedel's law. We have shown how these difficulties may be overcome, even in the limit of a flat Ewald sphere, by the imposition of appropriate consistency conditions. These enable the determination of the relative orientations of the diffraction patterns, and hence the molecular structure, to within the usual enantiomeric uncertainty.

We have tested the algorithm with a computer simulation for a model protein, at an X-ray wavelength short enough to justify the flat Ewald-sphere approximation, with and without Poisson noise for the detected photons. Adaptation of this algorithm to take account of curved common lines can readily

extend the applicability of this approach to longer X-ray wavelengths.

Our simulations have highlighted an important limitation of a common-line method for finding the relative orientations of diffraction patterns from random orientations of a sample. Such methods depend on comparing the intensity distributions along particular lines in two diffraction patterns, thus using only a very small fraction of the available data for each orientation determination. They are consequently very sensitive to noise.

We find that the common-line method ceases to work reliably for mean photon counts per pixel below about 10 in the high-*q* part of a diffraction pattern. These regions contain the high-resolution information needed to resolve the secondary structure of a protein. Since the scattering by a typical (500 kDa) protein of a pulse from a planned XFEL beam focused to a spot of 0.1 µm diameter is expected to produce some 1000× fewer photons per detector pixel, the use of a common-line method would seem to necessitate the classification and averaging of at least 1000 low-intensity diffraction patterns per orientational class to correctly assemble the scattered intensity distribution in three-dimensional reciprocal space.

The method of classifying diffraction patterns into orientational classes examined by Bortel & Faigel (2007) requires at least 100× the anticipated XFEL fluence. Even if superior classification methods were devised, the determination of the structure of a 100 Å-wide molecule to 3 Å resolution would require about 10⁶ orientational classes (Bortel & Faigel, 2007). Assuming pulse and readout rates of 100 Hz, data collection for a 500 kDa protein would require several months of continuous beam time.

We thank Veit Elser, Leonard Feldman, Paul Fuoss, John Spence and Brian Stephenson for helpful discussions.

References

- Abela, R., Aghababayan, A., Altarelli, M., Altucci, C., Amatuni, G., Anfinrud, P., Audebert, P., Ayvazyan, V., Baboi, N., Baehr, J., Balandin, V., Bandelmann, R., Becker, J., Beutner, B., Blome, C. *et al.* (2007). *The European X-ray Free-Electron Laser. Technical Design Report*, edited by M. Altarelli, R. Brinkmann, M. Chergui, W. Decking, B. Dobson, S. Düsterer, G. Grübel, W. Graeff, H. Graafsma, J. Hajdu, J. Marangos, J. Pflüger, H. Redlin, D. Riley, I. Robinson *et al.*, pp. 401–420. http://xfel.desy.de/tdr/index_eng.html.
- Bortel, G. & Faigel, G. (2007). *J. Struct. Biol.* **158**, 10–18.
- Chapman, H. N. (2007). Personal communication.
- Chapman, H. N., Barty, A., Marchesini, S., Noy, A., Hau-Riege, S. P., Cui, C., Howells, M. R., Rosen, R., He, H., Spence, J. C. H., Weierstall, U., Beetz, T., Jacobsen, C. & Shapiro, D. (2006). *J. Opt. Soc. Am.* **23**, 1179–1200.
- Cooley, J. W. & Tukey, J. W. (1965). *Math. Comput.* **19**, 297–301.
- Cramer, P., Bushnell, D. A. & Kornberg, R. D. (2001). *Science*, **292**, 1863–1876.
- Cromer, D. T. & Mann, J. B. (1968). *Acta Cryst.* **A24**, 321–324.
- Delaunay, B. (1934). *Isv. Acad. Nauk SSSR Otdelenie Math. Estestvennykh Nauk*, **7**, 793–800.
- Elser, V. (2003). *J. Opt. Soc. Am. A*, **20**, 40–55.
- Farrow, N. A. & Ottensmeyer, F. P. (1992). *J. Opt. Soc. Am. A*, **9**, 1749–1760.

¹ An alternative approach has been proposed by Spence *et al.* (2005) for improving the signal-to-noise ratio, in which the orientational alignment of the molecules is controlled by means of crossed laser beams.

- Fenn, J. B. (2002). *J. Biomol. Tech.* **13**, 101–118.
- Fienup, J. R. (1978). *Opt. Lett.* **3**, 27–29.
- Fienup, J. R. (1982). *Appl. Opt.* **21**, 2758–2769.
- Frank, J. (2006). *Three-Dimensional Electron Microscopy of Macromolecular Assemblies*. Oxford University Press.
- Fung, R., Shneerson, V. L., Lyman, P. F., Parihar, S. S., Johnson-Steigelman, H. T. & Saldin, D. K. (2007). *Acta Cryst.* **A63**, 239–250.
- Gnatt, A. L., Cramer, P., Fu, J., Bushnell, D. A. & Kornberg, R. D. (2001). *Science*, **292**, 1876–1882.
- Goncharov, A. B., Vainshtein, B. K., Ryskin, A. I. & Vagin, A. A. (1987). *Sov. Phys. Crystallogr.* **32**, 504–509.
- Hajdu, J., Hodgson, K., Miao, J., van der Spoel, D., Neutze, R., Robinson, C. V., Faigel, G., Jacobsen, C., Kirz, J., Sayre, D., Weckert, E., Materlik, G. & Szöke, A. (2000). *Structural Studies of Single Particles and Biomolecules, LCLS: The First Experiments*, pp. 35–62, http://www-ssrl.slac.stanford.edu/lcls/papers/lcls_experiments_2.pdf.
- Heel, M. van (1987). *Ultramicroscopy*, **21**, 111–124.
- Hegerl, R. & Hoppe, W. (1976). *Z. Naturforsch. Teil A*, **31**, 1717–1721.
- Huldt, G., Szöke, A. & Hajdu, J. (2003). *J. Struct. Biol.* **144**, 218–227.
- Jurek, Z., Faigel, G. & Tegze, M. (2004). *Eur. Phys. J.* **29**, 217–229.
- Kumpf, C., Marks, L. D., Ellis, D., Smilgies, D., Landemark, E., Nielsen, M., Feidenhans'l, R., Zegenhagen, J., Bunk, O., Zeysing, J. H., Su, Y. & Johnson, R. L. (2001). *Phys. Rev. Lett.* **86**, 3586–3589.
- McEwen, B. F., Downing, K. H. & Glaeser, R. M. (1995). *Ultramicroscopy*, **60**, 357–373.
- Marchesini, S., He, H., Chapman, H. N., Hau-Riege, S. P., Noy, A., Howells, M. R., Weierstall, U. & Spence, J. C. H. (2003). *Phys. Rev. B*, **68**, 140101(R).
- Miao, J., Hodgson, K. & Sayre, D. (2001). *Proc. Natl Acad. Sci. USA*, **98**, 6641–6645.
- Millane, R. P. (2003). *Proc. Oceans 2003, CD ROM, IEEE*, pp. 2714–2719.
- Neutze, R., Wouts, R., van der Spoel, D., Weckert, E. & Hajdu, J. (2000). *Nature (London)*, **406**, 752–757.
- Normille, D. (2006). *Science*, **314**, 751–752.
- Oszlányi, G. & Sütő, A. (2004). *Acta Cryst.* **A60**, 134–141.
- Oszlányi, G. & Sütő, A. (2005). *Acta Cryst.* **A61**, 147–152.
- Ourmazd, A., Fung, R., Shneerson, V. L. & Saldin, D. K. (2007). *Coherence 2007, International Workshop on Phase Retrieval and Coherent Scattering, Asilomar, California, USA*.
- Saldin, D. K., Shneerson, V. L., Fung, R. & Ourmazd, A. (2007). *Coherence 2007, International Workshop on Phase Retrieval and Coherent Scattering, Asilomar, California, USA*.
- Shapiro, D., Thibault, P., Beetz, T., Elser, V., Howells, M., Jacobsen, C., Kirz, J., Lima, E., Miao, H., Nieman, A. M. & Sayre, D. (2005). *Proc. Natl Acad. Sci. USA*, **102**, 15343–15346.
- Solem, J. C. & Baldwin, G. C. (1982). *Science*, **218**, 229–235.
- Spence, J. C. H., Schmidt, K., Wu, J. S., Hembree, G., Weierstall, U., Doak, B. & Fromme, P. (2005). *Acta Cryst.* **A61**, 237–245.
- Thibault, P., Elser, V., Jacobsen, C., Shapiro, D. & Sayre, D. (2006). *Acta Cryst.* **A62**, 248–261.
- Williams, G. J., Pfeifer, M. A., Vartanyants, I. A. & Robinson, I. K. (2003). *Phys. Rev. Lett.* **90**, 175501.
- Wu, J. S., Spence, J. C. H., O’Keefe, M. & Groy, T. L. (2004). *Acta Cryst.* **A60**, 326–330.
- Wu, J. S., Weierstall, U., Spence, J. C. H. & Koch, C. T. (2004). *Opt. Lett.* **29**, 2737–2739.
- Wu, J., Weierstall, U. & Spence, J. C. H. (2005). *Nature Materials*, **4**, 912–916.